

FORD RANGER MOBILE MAINTENANCE VEHICLE



VEHICLE SUMMARY

A heavy duty, pickup based, mobile maintenance vehicle for all terrain with a range of flexible equipment packages mounted in six lockable compartments designed to prevent water and dust ingress and available for unsupported operations in challenging environments and remote locations.



Vehicle Details

| | |
|--------------------|------------------------|
| Manufacturer | Ford |
| Model | Ranger Single Cab |
| Engine type | Turbo Diesel 2.2L TDCi |
| Power (kW/PS) | 88/120 @ 3,700 rpm |
| Torque (Nm) | 285 @ 1,750-2,300 rpm |
| Drivetrain | 4X4 |
| Transmission | 5-speed manual |
| Fuel tank capacity | 80L |
| Wheels | 16" steel wheel |
| Tires | All terrain |

Dimensions of Modified Vehicle (mm)

| | |
|------------------------|------|
| Length | 5401 |
| Width | 1880 |
| Height | 2023 |
| Angle of approach (°) | 30 |
| Angle of departure (°) | 30.3 |
| Wheelbase | 3220 |
| Track width | 1560 |
| Ground clearance | 201 |
| Turning circle (m) | 12 |

Weight Table (kg)

| | |
|--------------------------------------|--------|
| Base vehicle unladen kerb weight | 1880 |
| Modified vehicle unladen kerb weight | 2595 |
| 1) Front axle | 1243.4 |
| 2) Rear axle | 1351.6 |
| Payload capacity | 605 |
| Gross modified vehicle weight | 3200 |

Contact RMA Automotive for more information or a quotation.

✉ inquiries@rmagroup.net 🌐 rmaautomotive.net



ARMOR FEATURES



Front protection bull bar



Interior storage for large equipment



Multiple storage lockers with easy access to equipment



Lockable doors



Multiple storage lockers

STANDARD FEATURES

- Multipurpose service body
- Lockable roller shutter side and rear door
- Interior lighting & tail lights (maintenance)
- Enhanced handling suspension package (high load)

- Enhanced fuel filtration system (warm climate)
- Deep cycle battery (split charge, maintenance)
- Fire extinguisher (1kg, cabin mount)
- Safety kit 1 (first aid kit & warning triangle)

OPTIONAL FEATURES

- Air compressor
- Air intake snorkel
- Amber beacon light (roof mount)
- Bull bar
- Crane (maintenance)
- Electric front winch (10,000 lbs or 4,500 kg)
- Fire extinguisher (1kg, cabin mount)
- Gas cutting & welding equipment
- Grease pump
- Heavy duty battery
- Heavy duty brake discs & pads (front)
- Heavy duty side rails

- Heavy duty side steps
- Hi-lift jack
- Long range fuel tank (115L)
- Oil tank (60L)
- Power welder generator (fixed)
- Recovery pack
- Tool set (157 multi-piece)
- Tool set (socket wrench set)
- Tow bar (ball/ball-pintle/pintle)
- Vice (maintenance body)
- Water tank (29L)

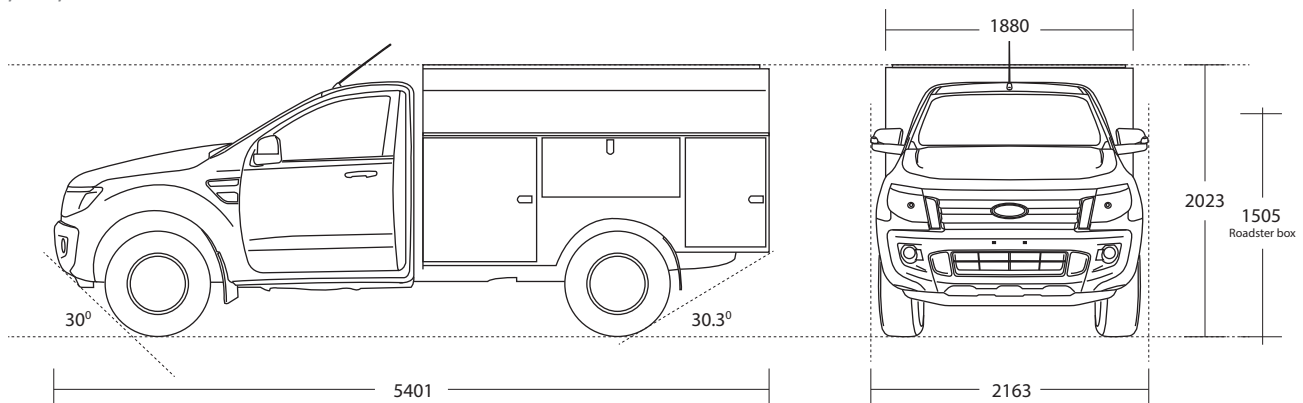

Notes:
 The company reserves the right to change the vehicle specifications and features described in this publication at any time.
 Vehicle specifications and features may vary in different markets.
 Images are for illustrative purposes only and may appear different to the actual vehicle.

Contact RMA Automotive for more information or a quotation.

✉ inquiries@rmagroup.net 🌐 rmaautomotive.net

